

Company: Joyoung International Trading Co., Limited

Atten: Smiling

Mobile/WhatsApp/Wechat: +86 18050035902

E-mail: info@htechplc.com

Website: <https://www.joyoungintl.com/>

MEGGITT

Enabling the Extraordinary
To Fly To Power To Live

DATA SHEET

vibro-meter®

CE620 piezoelectric accelerometer with integrated electronics



CE620
(sensor only version)



KEY FEATURES AND BENEFITS

- From the vibro-meter® product line
- Voltage output signal: 100 or 500 mV/g
- Frequency response:
 - 0.5 to 14000 Hz (100 mV/g versions)
 - 0.2 to 3700 Hz (500 mV/g versions)
- Temperature range:
 - 55 to 120°C (100 mV/g versions)
 - 55 to 90°C (500 mV/g versions)
- Isolated electronics with internal shield for reduced noise and improved bias-voltage stability
- Ground isolated from case
- Available as a sensor only or with an integral cable
- Available in standard versions and Ex versions certified for use in hazardous areas

APPLICATIONS

- General-purpose vibration monitoring in harsh industrial environments and/or hazardous areas

DESCRIPTION

The CE620 piezoelectric accelerometer with integrated electronics from Meggitt's vibro-meter® product line is a general-purpose vibration sensor designed for the monitoring and protection of machinery in harsh industrial environments.

The CE620 is an industry standard IEPE (integrated electronics piezo electric) vibration sensor that requires a constant current power supply and provides a dynamic vibration output signal (AC voltage) on a bias level (DC voltage). It is available with a sensitivity of either 100 or 500 mV/g.

The CE620 is available as a sensor only or fitted with an integral cable that is protected by a stainless-steel overbraid. Sensor only versions allow one of a range of different cable assemblies to be used to connect the sensor to the monitoring system, depending on the application and environment.

The CE620 is available in standard versions for use in standard (non-hazardous) areas and Ex versions for installation in hazardous areas (potentially explosive atmospheres).

For specific applications, contact your local Meggitt representative.



Information contained in this document may be subject to export control regulations of the European Union, USA or other countries. Each recipient of this document is responsible for ensuring that transfer or use of any information contained in this document complies with all relevant export control regulations. ECN N/A.

SPECIFICATIONS

Note: Unless otherwise stated, all values listed are typical values, referenced at 24°C (75°F).

Operating

Sensitivity

- 100 mV/g versions (ordering option code B100) : 100 mV/g \pm 5%
- 500 mV/g versions (ordering option code B500) : 500 mV/g \pm 5%

Dynamic range

- 100 mV/g versions : \pm 80 g peak
- 500 mV/g versions : \pm 16 g peak

Transverse sensitivity : <5%

Linearity : \pm 1% maximum

Frequency response

- 100 mV/g versions : 1 to 9000 Hz (\pm 10%).
0.5 to 14000 Hz (\pm 3 dB).
- 500 mV/g versions : 0.4 to 1600 Hz (\pm 10%).
0.2 to 3700 Hz (\pm 3 dB).

Resonant frequency

- 100 mV/g versions : 25 kHz nominal
- 500 mV/g versions : 16 kHz nominal

Temperature response (sensitivity deviation)

- -55°C (-67°F) : -10% typical
 - 120°C (-248°F) : +5% typical
- Note: Reference at 20°C (68°F).

Electrical

Power supply voltage (for current source) : 22 to 28 V_{DC}

Power supply current : 2 to 10 mA

Bias voltage (4 mA supply)

- 100 mV/g versions (ordering option code B100) : 12 V_{DC} nominal
- 500 mV/g versions (ordering option code B500) : 10 V_{DC} nominal

Output impedance : 50 Ω nominal

Residual electrical noise

- 100 mV/g versions : 30 μ g/ \sqrt Hz at 1 Hz, 6 μ g/ \sqrt Hz at 10 Hz,
5 μ g/ \sqrt Hz at 100 Hz, 5 μ g/ \sqrt Hz at 1000 Hz
- 500 mV/g versions : 20 μ g/ \sqrt Hz at 0.1 Hz, 6 μ g/ \sqrt Hz at 1 Hz, 2 μ g/ \sqrt Hz at 10 Hz,
2 μ g/ \sqrt Hz at 100 Hz, 2 μ g/ \sqrt Hz at 1000 Hz

Grounding : Isolated from case (machine ground), internally shielded

Internal isolation (case to shield) : 100 M Ω minimum

Reverse polarity : Protected

Overvoltage : Protected

SPECIFICATIONS *(continued)*

Environmental

Temperature range

- 100 mV/g versions (ordering option code B100) : -55 to 120°C (-67 to 248°F)
- 500 mV/g versions (ordering option code B500) : -55 to 90°C (-67 to 194°F)

Humidity : IP68 (according to IEC 60529)

Shock vibration limit : 5000 g peak



Continuous vibration limit : 500 g peak

Base strain sensitivity : 0.0002 g peak/ $\mu\epsilon$

Electromagnetic sensitivity (50 Hz, 0.03 T) : 0.2 g

Potentially explosive atmospheres

Available in Ex approved versions for use in hazardous areas

Type of protection Ex ia: intrinsic safety (ordering option code A2)		
Europe	EC type examination certificate	 I M1 Ex ia I Ma  II 1 GD (Zones 0, 1, 2, 20, 21, 22) Ex ia IIC T4 Ga Ex ia IIIC T135°C Da LCIE 20 ATEX 3039 X
International	IECEx certificate of conformity	Ex ia I Ma Ex ia IIC T4 Ga Ex ia IIIC T135°C Da IECEx LCIE 20.0026X
Russian Federation	EAЭC RU certificate of conformity*	PO Ex ia I Ma X OEx ia IIC T4 Ga X Ex ia IIIC T135°C Da X EAЭC RU C-CH.AΔ07.B.03042/21

*Not engraved/marked on the products.

 **For specific parameters of the mode of protection concerned and special conditions for safe use, refer to the Ex certificates that are available from Meggitt SA.**

 **For the most recent information on the Ex certifications that are applicable to this product, refer to the Ex product register (PL-1511) document that is available from Meggitt SA.**

Approvals

Conformity : European Union (EU) declaration of conformity (CE marking)

Electromagnetic compatibility (EMC) : EMC compliant (2014/30/EU). EN 61326-1.

Environmental management : RoHS compliant (2011/65/EU)

Hazardous areas : Ex approved versions (see **Potentially explosive atmospheres on page 3**)

SPECIFICATIONS *(continued)*

Physical

Case material	: Stainless steel (AISI 316L, DIN 1.4404)
Dimensions	: See Mechanical drawings starting on page 5
Weight	
• Sensor only versions	: 85 g (0.19 lb) approx.
• Integral cable versions	: 60 g/m (0.04 lb/ft) approx.

Connector

Sensor version	: Sensor only versions (PNR 444-620-000-111). See Sensor only versions on page 5 .
Connector type	: MIL-C-5015-10SL-4P – rugged circular, threaded coupling, 2-pin connector with keyway. Note: Mates with MIL-C/DTL-5015 type connectors, as used by the recommended cable assemblies.
Connector pinouts (pin allocation)	
• Pin A (+)	: Power supply and output signal
• Pin B (-)	: Common
Recommended cable assemblies	: EC318, EC319, EC622 and EC632 (see Accessories on page 7)

Cable

Sensor version	: Integral cable versions (PNR 444-620-000-211). See Integral cable versions on page 6 .
Cable type	: Cable: Teflon [®] FEP cable, twisted-pair shielded, $\varnothing 4.8 \pm 0.2$ mm. Conductors: 2×0.5 mm ² twisted cores. Overbraid: Stainless steel (AISI 316L). Outer diameter: $\varnothing 5.2 \pm 0.3$ mm (0.20"). Maximum temperature: 200°C (392°F). Weight: See Physical on page 4 .
Cable pinouts (flying lead allocation)	
• Red (+) wire	: Power supply and output signal
• White (-) wire	: Common

Mounting

Stud or adaptor	: 1/4"-28UNF-2A (see Accessories on page 7)
Torque	: 2.4 N•m (1.8 lb-ft). Refer also to the <i>CExx and PVxx vibration sensors (piezoelectric accelerometers and piezoelectric velocity sensors) installation manual</i> .

Calibration

Dynamic calibration at factory. No subsequent calibration necessary.

MECHANICAL DRAWINGS

Sensor only versions

CE620 accelerometer

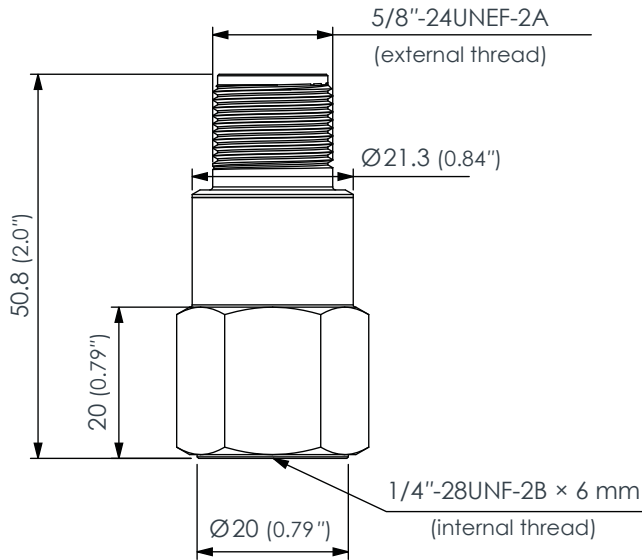

Adaptor studs

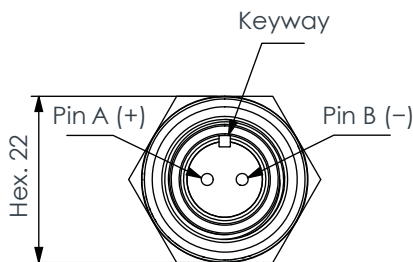
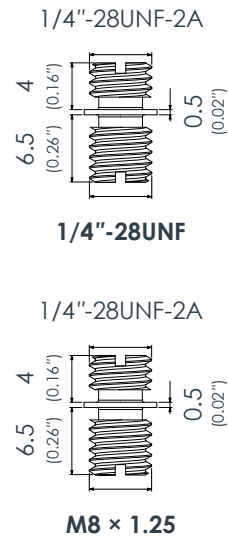

Notes

All dimensions in mm (in) unless otherwise stated.

For the sensor only versions of the CE620, the sensor mates with MIL-C/DTL-5015 type connectors.

Not all combinations of sensor ordering option codes (A, B and C) are available.

See also **Ordering information on page 7** and the ECxxx cable assemblies in **Accessories on page 7**.

Ordering number (PNR):

444 - 620 - 000 - 111 - **A** - **B** - **C**

Environment (A)	
Standard	1
Explosive (Ex)	2

Sensitivity (B)	
100 mV/g	100
500 mV/g	500

Connector (C)	
01	MIL-C-5015-10SL-4P

MECHANICAL DRAWINGS (continued)

Integral cable versions

CE620 accelerometer

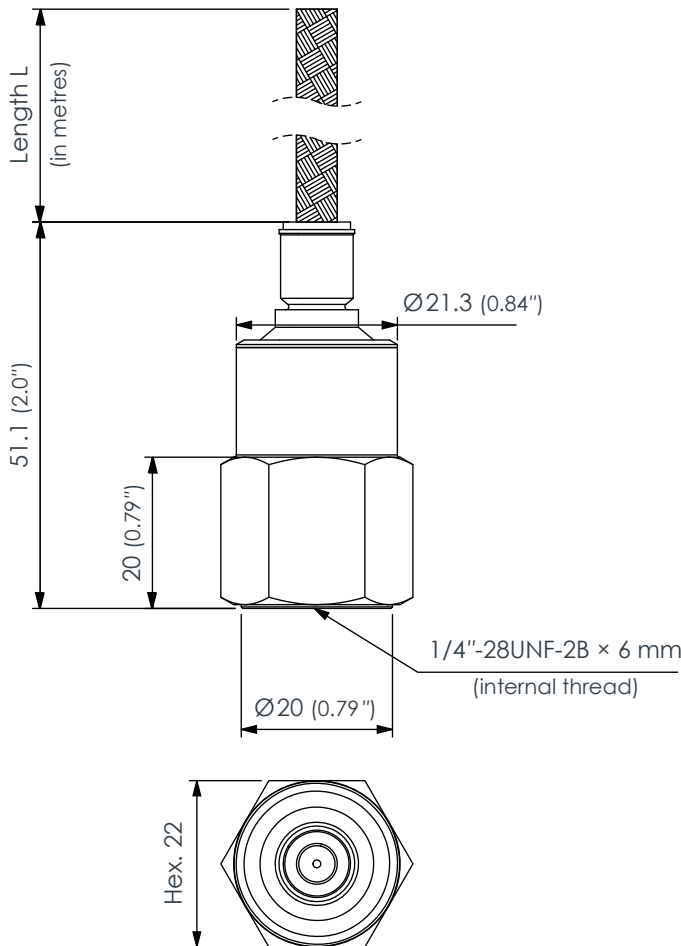

Adaptor studs

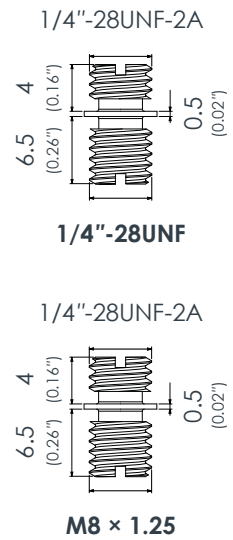

Notes

All dimensions in mm (in) unless otherwise stated.
 For the integral cable versions of the CE620, the length of cable is defined at the time of ordering.
 Not all combinations of sensor ordering option codes (A, B, C and L) are available.
 See also **Ordering number (PNR)** below and the **Ordering information on page 7**.

Ordering number (PNR):

444 - 620 - 000 - 211 - **A** - **B** - **C** - **L**

Environment (A)	
Standard	1
Explosive (Ex)	2

Sensitivity (B)	
100 mV/g	100

Integral cable length (L)	
05	5 m
10	10 m

Cable (C)	
72	Integral FEP cable with overbraid

ORDERING INFORMATION

To order, please specify the version(s) of the CE620 piezoelectric accelerometer with integrated electronics required ...

Standard (non-Ex) versions:

Type	Designation	Ordering number (PNR)
CE620	100 mV/g sensor only version	444-620-000-111-A1-B100-C01
CE620	500 mV/g sensor only version	444-620-000-111-A1-B500-C01
CE620	100 mV/g integral cable version – 5 m cable length	444-620-000-211-A1-B100-C72-L05
CE620	100 mV/g integral cable version – 10 m cable length	444-620-000-211-A1-B100-C72-L10

Ex versions (for use in hazardous areas):

Type	Designation	Ordering number (PNR)
CE620	100 mV/g sensor only version	444-620-000-111-A2-B100-C01
CE620	100 mV/g integral cable version – 5 m cable length	444-620-000-211-A2-B100-C72-L05
CE620	100 mV/g integral cable version – 10 m cable length	444-620-000-211-A2-B100-C72-L10

Notes

Only CE620 sensors with the specific ordering numbers (PNRs) listed above are available to order. That is, not all combinations of sensor ordering option codes (A, B, C and L) are available. For example, Ex versions of the CE620 sensor with a sensitivity of 500 mV/g are not available.

ACCESSORIES

Supplied

Item	Type	Part number (PNR)
• Adaptor studs	1/4"-28UNF (1/4"-28UNF-2A to 1/4"-28UNF-2A)	809-601-000-011
	M8 × 1.25 (1/4"-28UNF-2A to M8 × 1.25)	809-601-000-021

Note: One of each of these type of adaptor studs is supplied with a CE620, that is, one M8 × 1.25 and one 1/4"-28UNF.

Optional

Item	Type	Part number (PNR)
• Adaptor studs	M8 × 1 (1/4"-28UNF-2A to M8 × 1)	809-601-000-031

ACCESSORIES (continued)

Optional (continued)

Item	Type	Part number (PNR)
• Cable assemblies	EC318. Standard version with a 2-pin MIL-C/DTL-5015 type connector, 2-wire RADOX [®] cable.	922-318-000-002
	EC318. Standard version with a 2-pin MIL-C/DTL-5015 type connector, 2-wire RADOX [®] cable and cable protection (flexible stainless-steel hose).	922-318-000-403
	EC319. Splashproof version with a 2-pin MIL-C/DTL-5015 type connector, 2-wire RADOX [®] cable.	922-319-000-002
	EC319. Splashproof version with a 2-pin MIL-C/DTL-5015 type connector, 2-wire RADOX [®] cable and cable protection (sealed, flexible stainless-steel hose).	922-319-000-103
	EC622. Standard version with a 2-pin MIL-C/DTL-5015 type connector, 2-wire Polyurethane (PUR) cable, IP67 cable boot (overmold).	922-622-000-001
	EC632. Higher-temp. version with a 2-pin MIL-C/DTL-5015 type connector, 2-wire Teflon [®] FEP cable, IP67 cable boot (overmold).	922-632-000-001
	EC632. Higher-temp. version with a 2-pin MIL-C/DTL-5015 type connector, 2-wire Teflon [®] FEP cable, IP67 cable boot (overmold) and cable protection (stainless steel (AISI 316L) overbraid).	922-632-000-101

Notes

The cable length must be specified when ordering a cable assembly.

When ordering a EC31x cable assembly, the ordering option code -L or -U is used to specify the overall cable length.
EC31x cable assemblies can be specified with any cable length.

When ordering a EC6x2 cable assembly, the ordering option code -L is used to specify the overall cable length.

EC6x2 cable assemblies must be specified with a standard length of 2, 5, 10, 15, 20 or 30 m (corresponding to ordering option codes of L2000, L5000, L10000, L15000, L20000 or L30000, respectively).

Refer to the cable assembly product drawings for further information.

Item	Type	Part number (PNR)
• Mounting adaptor	MA122_012 (1/4"-28UNF-2A to M6, with a conic base)	809-122-000-012
• Insulating stud	MA122_021 (1/4"-28UNF-2A to M6, with a conic base)	809-122-000-021

RELATED PRODUCTS

CE630	Piezoelectric accelerometer (100 or 500 mV/g output, side connector)	: Refer to corresponding data sheet
CE687	Piezoelectric accelerometer (4 to 20 mA output proportional to g)	: Refer to corresponding data sheet
PV660	Piezoelectric velocity sensor (4 mV/mm/s output)	: Refer to corresponding data sheet
PV685	Piezoelectric velocity sensor (4 to 20 mA output proportional to mm/s)	: Refer to corresponding data sheet